

Transportable Monitoring and Direction Finding Systems R&S TMS 100/R&S TMS 200

For mobile, stationary, remote-controlled and portable use

- ◆ Reliable solution for monitoring and direction finding between 20 MHz and 1300 MHz, with extendable range from 10 kHz (500 kHz for DF) to 3000 MHz
- ◆ Compact and cost-effective
- ◆ Different power supplies available: 100 V to 240 V AC or 11 V to 32 V DC
- ◆ Can easily be carried by two persons
- ◆ Quickly ready for use because of the very short setup time
- ◆ Can be operated up to 24 hours per day
- ◆ Controlled via Monitoring Software R&S ARGUS



ROHDE & SCHWARZ

Introduction

In some cases, the use of fixed or mobile monitoring stations is either not practical or too expensive. The following example will explain this.

There are cases where radio interference due to intended or unintended emissions occurs only very rarely (e.g. once every few weeks). However, the radio service affected can be so important that it is absolutely essential to eliminate the interferer. Someone might, for example, send pilots of overflying aircraft the wrong navigation information using a portable, tunable transceiver and so pose a threat to life. In a case like this, the affected frequency must be monitored over a long period of time. The technical parameters of all emissions received must be determined and automatically compared to previous data to filter out known stations (towers or aircraft) as far as possible so that only information about "suspicious emissions" is passed on to the appropriate monitoring station operators.

If the interferer is not in the receive range of the fixed monitoring stations, these stations cannot be used. Usually, mobile monitoring stations powered by their own supply cannot be left unattended over an extended period of time. These restrictions also apply to all other monitoring tasks that require long-term measurements beyond the receive range of fixed or remote-controlled monitoring stations and where the permanent presence of control staff is too complicated or too expensive for reasons of logistics.

This is where transportable monitoring stations come into their own. They can perform all the measurement tasks usually associated with fixed or remote-controlled monitoring stations and have the extra advantages of being much more cost-effective and capable of changing location rapidly. This means that the coverage area of a network comprising fixed and remote-controlled monitoring stations can be expanded according to user requirements.

An approach to the interference problem described above would be to position a transportable monitoring station directly below the air traffic route concerned, e.g. on the approach track to the runway. All aircraft emissions would then come from the same direction and could be filtered out by the monitoring software. The tower emissions could also be filtered out. The transportable monitoring station alarms the control station only if it detects a targeted emission. If the interferer is reported without an alarm being issued, the transportable monitoring station was not in the receive range of the interferer and must be moved. However, if the interferer has been received once, the transportable monitoring station can be shifted and the filter for triggering the alarm can be set to characteristic features, e.g. frequency offset. The transportable monitoring station can, therefore, be positioned closer and closer to the interferer until it is possible to use a vehicle for exact radiolocation.

Countries just starting with frequency monitoring may also use the transportable monitoring systems as a cost-effective alternative to fixed or mobile monitoring stations.

Overview

Tasks

The Transportable Monitoring and Direction Finding Systems R&S TMS100 and R&S TMS200 are optimized for mobile use at rapidly changing sites with unknown radio scenarios. They are designed for the following monitoring and DF tasks from 20 MHz to 1300 MHz, with extendable range from 10 kHz (500 kHz for DF) to 3000 MHz:

- ◆ Investigations of interference due to co-channel emissions, out-of-channel emissions and intermodulation
- ◆ Short-term and long-term monitoring of technical transmitter parameters such as field strength and frequency offset
- ◆ Field strength measurements
- ◆ Identification of unlicensed stations
- ◆ Spectrum occupancy measurements

All measurement tasks can be performed either automatically (scheduled) or interactively.

Transport

A portable rack neatly accommodates all the equipment for ease of transportation and provides weather protection when the equipment is taken out of doors. As with other items, such as antennas, no more than two persons are needed to carry the portable rack.

Setup time

Fast on-site setup is ensured because both hardware and software are always ready to use. It is simply a question of setting up the antennas, connecting the cables and switching everything on. Measurements can then be performed for an unlimited period of time.

Power supply

To ensure maximum flexibility and adaptability to all applications and environmental conditions, the systems come with dual power supply:

- ◆ 100 V to 240 V AC
- ◆ 11 V to 32 V DC

The systems can be powered not only from the AC supply, but also from vehicles or external batteries.

Standardization and modularization

The transportable systems are standardized to provide a cost-effective solution. However, to respond to different user requirements, the systems are also modular.

Applications

The Transportable Systems R&S TMS100 and R&S TMS200 have special features so that they can be used as attended or unattended fixed stations, as mobile stations or even as portable monitoring stations.

Operation as an attended fixed monitoring station

The key advantage of transportable systems over fixed monitoring stations is that once the allotted tasks at one site have been completed, a transportable system can be moved to another site and quickly set up. Owing to the system's compact

design, it can even be installed on roofs or in difficult terrain. The antennas can be mounted on tripods. Depending on the task, the frequency range and the polarization of the signals to be measured, one or more monitoring or DF antennas are connected to the system.

The main advantage of fixed monitoring systems over transportable systems is that heavy, bulky equipment can be used, e.g. a large antenna array for HF direction finders. If this is not necessary, the transportable system is a cost-effective alternative.



R&S TMS200 with options, operated as a fixed monitoring station

Operation as an unattended fixed monitoring station

Operation as an unattended fixed station and operation as an attended fixed station are essentially the same. Routers and modems as additional components are integrated into the transportable systems to enable remote control.

Analog or digital dialling or leased lines or GSM/GPRS 900/1800 links are used with a data rate of at least 9.6 kbps.

A control station can be created from a PC with the appropriate software, a router and a modem, or even from a transportable system when provided with the necessary communications equipment.

Direction finding can be performed with at least two transportable systems.

Operation as a mobile monitoring station

The transportable system can be installed in all vehicle types and so can be used as a mobile monitoring system. The portable rack containing the equipment can be easily fixed to the vehicle with four screws.

Special fixtures are used to mount the DF and monitoring antennas on the roof of the vehicle.

GPS receiver and compass can be added on to the system so that location and bearing of the vehicle can be determined automatically. The transportable system installed in vehicles can, of course, also be remote-controlled. This is usually done via GSM/GPRS 900/1800 links.

The system can be used even if the vehicle is moving. Antennas which are capable of withstanding the resulting forces must be mounted on the vehicle.

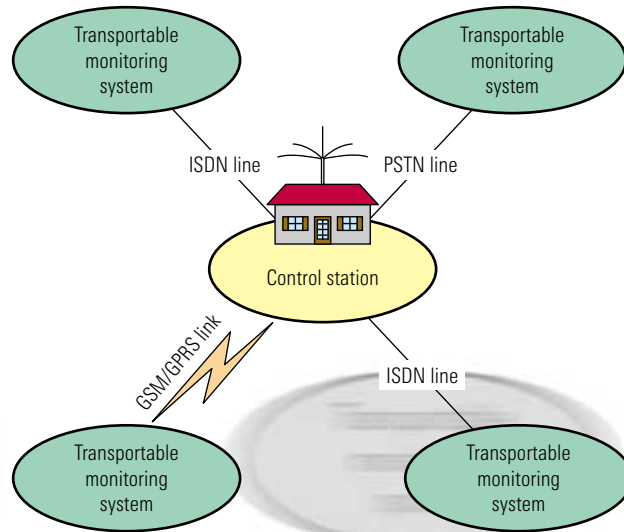

Four transportable systems operated as remote-controlled, unattended fixed monitoring stations

R&S TMS 200 with options, installed in a vehicle



Operation as a portable monitoring station

Due to its modular design, the Transportable Systems R&S TMS100 and R&S TMS200 can also be used as portable monitoring stations. All this involves is removing the Receiver R&S EB200 from the portable rack. The receiver is powered from a battery which is fixed to its base and so is easy to replace. A spare battery is charged by the transportable system. A bag is provided to allow convenient carrying of the receiver as well as protection from the weather. The Active Directional Antenna R&S HE200 is connected to the receiver and can be carried with one hand.

The receiver can be operated in three different modes, see box on right.



1. The DIGI-Scan gives the operator an overview of the frequency spectrum occupancy. The receiver is quickly tuned to any of the observed frequencies and switched to the listen mode with a single keystroke.

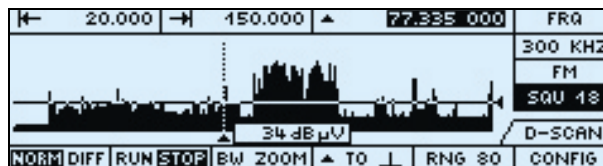

DIGI-Scan spectrum display

2. The differential mode of the DIGI-Scan is used for fast detection of changes in the frequency spectrum. When this mode is called, the current spectrum is stored as a reference. Changes in the spectrum are easily detected as up or down peaks.

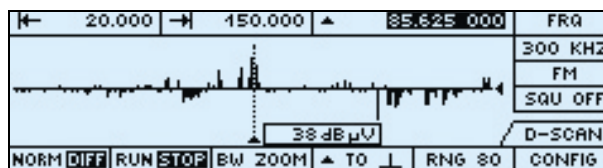

Differential mode of DIGI-Scan

3. With the directional antenna, the bearing of the signal source can be determined by means of the level display and/or the level-dependent tone.

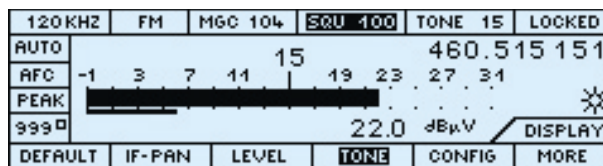

Level display on receiver

Any significant frequencies that are found can be stored in the receiver with a single keystroke.



Removal of receiver from rack and use as a portable monitoring station

System configuration

The R&S TMS 100 includes the Miniport Receiver R&S EB200, the compact System Process Controller R&S SPCC and the communication unit in a portable rack. The system can be connected to an antenna. The communication unit can comprise equipment for a network connection via a dialled or leased PSTN line (model 02), a dialled ISDN line (model 03) or a GSM/GPRS 900/1800 link (model 04).

The R&S TMS200 contains the System Notebook R&S SPCN instead of the compact System Process Controller R&S SPCC and the communication unit. The notebook can also be used in the office for further evaluations of the measurement results.

The block diagrams show the structure and the commercial-off-the-shelf components used of the R&S TMS 100 and the R&S TMS200.

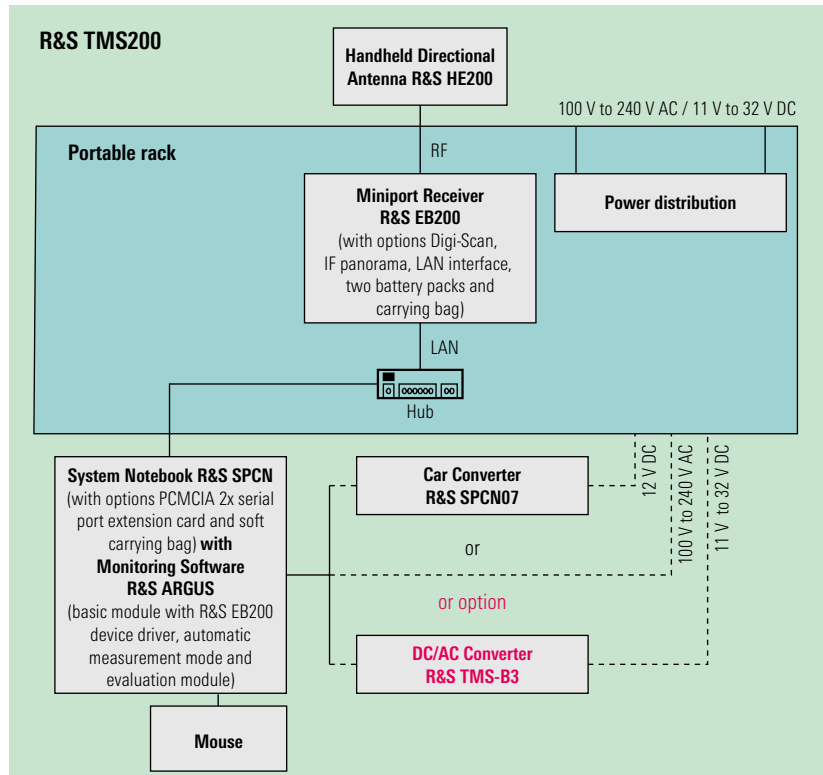

Block diagram of R&S TMS200

Block diagram of R&S TMS100

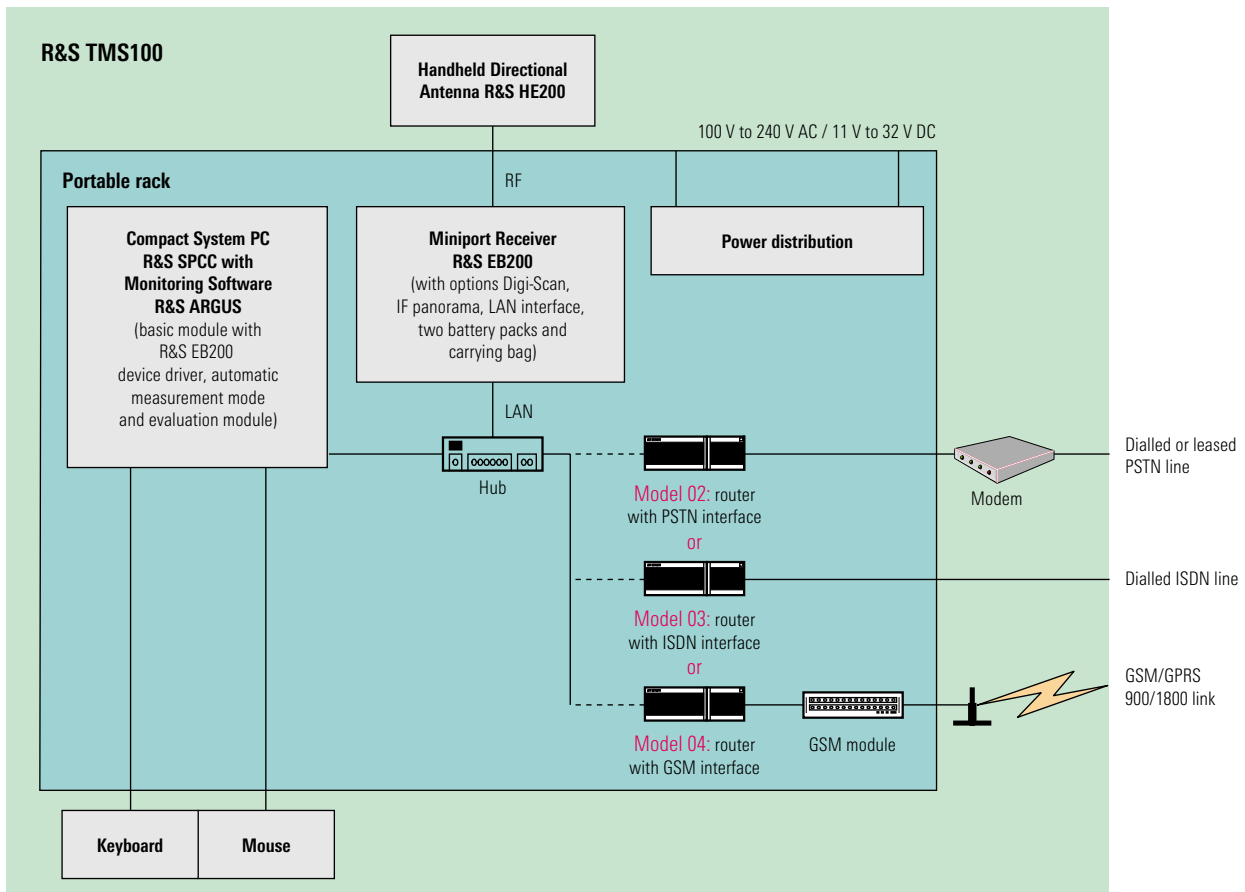

To fulfill all potential requirements of the customer, additional hardware is available such as direction finder, antennas, extensions of the frequency range, additional communication equipment, compass, GPS receiver or additional software packages to enhance the functionality.

In contrast to the R&S TMS 100, the R&S TMS200 can include the Switch Unit R&S ZS129A1 and use the Transportable Communication System R&S TMS-C.

The following options are available:

Option	R&S TMS 100	R&S TMS200
Options for R&S ARGUS: additional modules and interfaces	✓	✓
R&S MapView for displaying bearing results on digital maps	✓	✓
R&S AllAudio for transferring, recording, archiving, distributing and replaying audio	✓	✓
Handheld Directional Antenna R&S HE200HF (10 kHz to 20 MHz)	✓	✓
Switch Unit R&S ZS129A1 with rack integration kit and R&S ARGUS device driver ZS12x		✓
DF Processor R&S EBD 195 with rack integration kit, DF Antenna R&S ADD 195 (20 MHz to 1300 MHz) and R&S ARGUS device driver DDF1xx	✓	✓
DF Antenna R&S ADD 119 (0.5 MHz to 30 MHz)	✓	✓
DF Antenna R&S ADD071 (1.3 GHz to 3 GHz)	✓	✓
Antenna cable sets for DF antennas for different lengths and frequency ranges	✓	✓
Tripod R&S AP502Z2 with adapter for R&S ADD 195 or R&S ADD 119	✓	✓
Adapter for R&S ADD071 mounted on Tripod R&S AP502Z2	✓	✓
Grounding set for one antenna	✓	✓
Handheld compass for adjustment of DF antennas to magnetic north	✓	✓
Electronic Compass R&S GH 150 for automatic north correction of bearing results (only with R&S ADD 195)	✓	✓
Roof rack adapter for DF Antenna R&S ADD 195	✓	✓
Monitoring antennas for different frequency ranges and polarizations	✓	✓
Antenna cables for monitoring antennas for different lengths and frequency ranges	✓	✓
Tripod and adapter for monitoring antennas	✓	✓
GPS receiver and R&S ARGUS device driver GPS for automatic determination of system location	✓	✓
Battery to operate the system without any connection to a power supply	✓	✓
Case for R&S SPCN		✓
Case for cables	✓	✓
Monitors or TFT displays for R&S SPCC	✓	
External DC/AC converter from 11 V to 32 V DC to 230 V AC for connecting an R&S SPCN or a monitor directly to the portable rack	✓	✓
Front and rear cover for portable rack with opening for cables and fan, allowing the system to be operated with the portable rack closed	✓	✓
Transportable Communication System R&S TMS-C		✓



Front view of R&S TMS200 with options

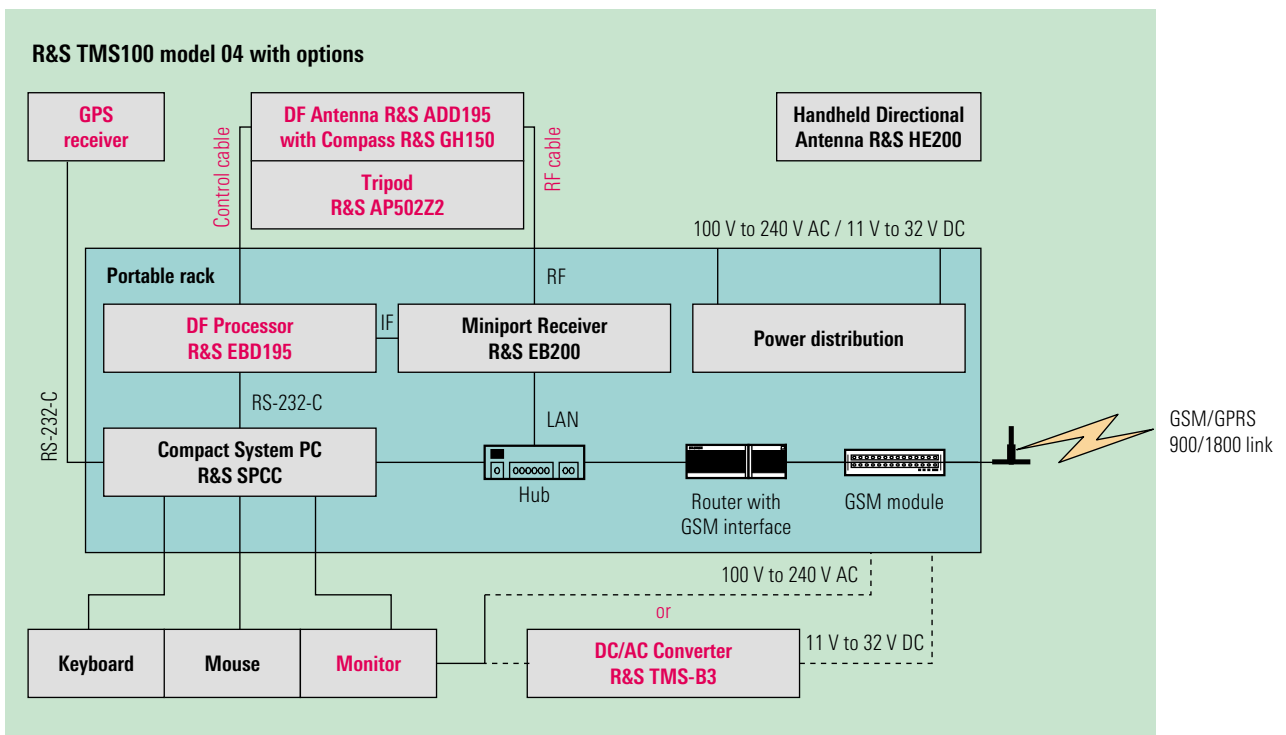

Example of an R&S TMS100 model 04 with options

R&S TMS200 with options

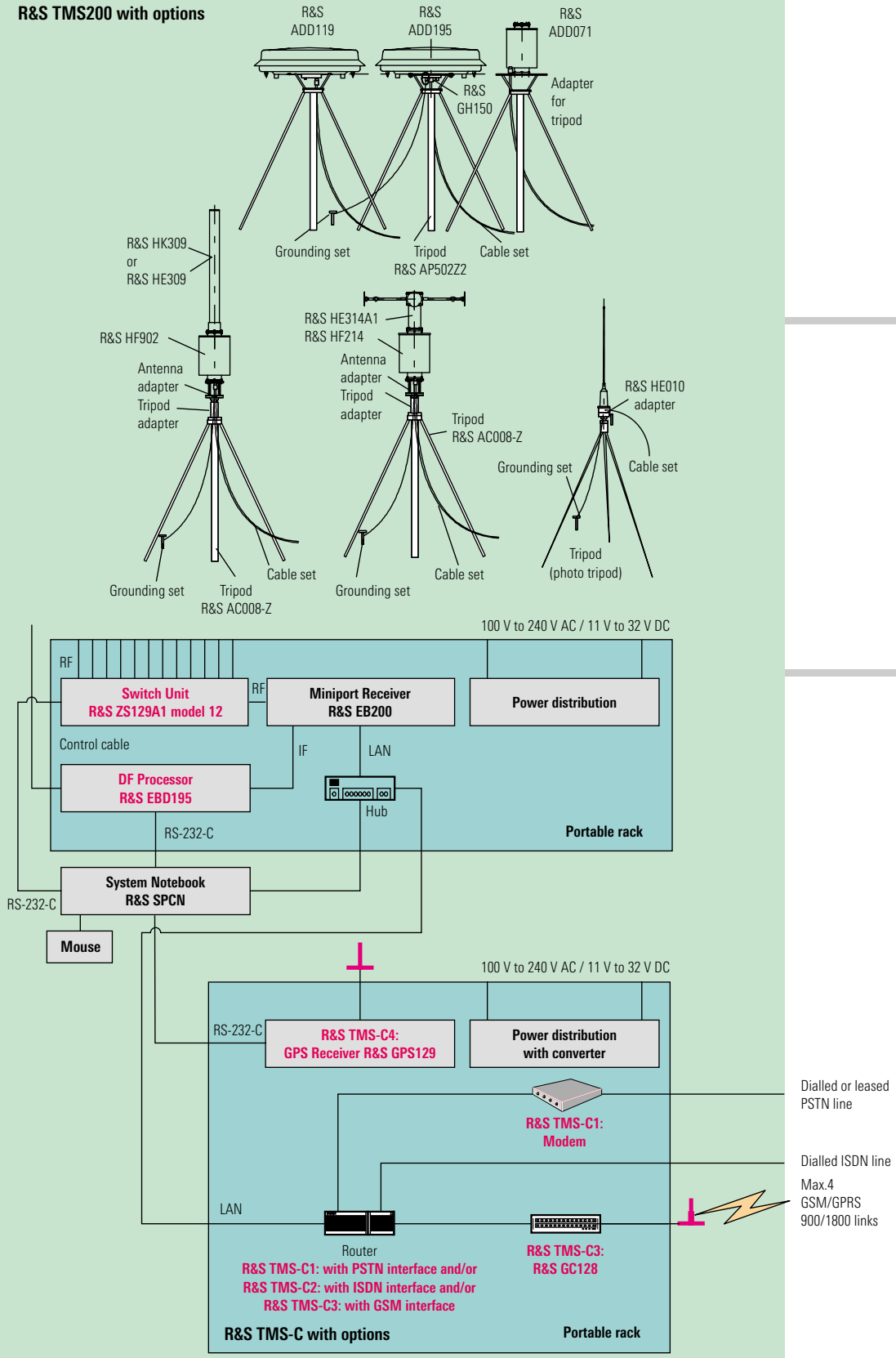

Example of an R&S TMS200 with options

Hardware components

For detailed information about the hardware, please refer to the following data sheets or technical informations:

- ◆ Data sheet R&S ARGUS-IT
- ◆ Data sheet R&S EB 200
- ◆ Data sheet R&S DDF 195
- ◆ Data sheet R&S ZS 129x
- ◆ Technical information R&S SPCx
- ◆ Technical information R&S TMS-C

For more information on the monitoring antennas, please refer to the relevant data sheets.

Software components

The Monitoring Software R&S ARGUS is included in the basic models with direct measurement mode, automatic measurement mode and evaluation module. Additional software modules of R&S ARGUS, R&S MapView and R&S AllAudio are available on request.

Monitoring Software R&S ARGUS

R&S ARGUS comprises numerous facilities for measuring, monitoring, identifying and direction finding according to ITU recommendations.

The **direct measurement mode** makes it possible to control all the equipment interactively via virtual front panels. This mode provides the operator with a fast way to monitor, measure, locate and identify emissions. In this mode, the following types of measurement are available:

◆ Fixed frequency mode (FFM)

The receiver is tuned to one frequency. The measurement results (level and offset) are displayed. In addition, IF analysis and direction finding (together with R&S DDF 195) can be performed.

◆ Digi-Scan

The receiver scans very fast from start frequency to stop frequency. The measurement results (level) are displayed in a Cartesian diagram and a 2D waterfall diagram. This is the most important mode and enables the user to get an overview over the spectrum and to analyze the signals.

◆ Scan

The receiver scans from start frequency to stop frequency using frequency increments. The measurement results (level and offset) are displayed in a Cartesian diagram, a 3D waterfall diagram or a 2D waterfall diagram with additional frequency occupancy diagram.

◆ Frequency list scan

The receiver performs scans using frequencies from a frequency list. The measurement results (level and offset) are displayed in a Cartesian diagram or a 2D waterfall diagram with additional frequency occupancy diagram.

Virtual front panel of a direction finder

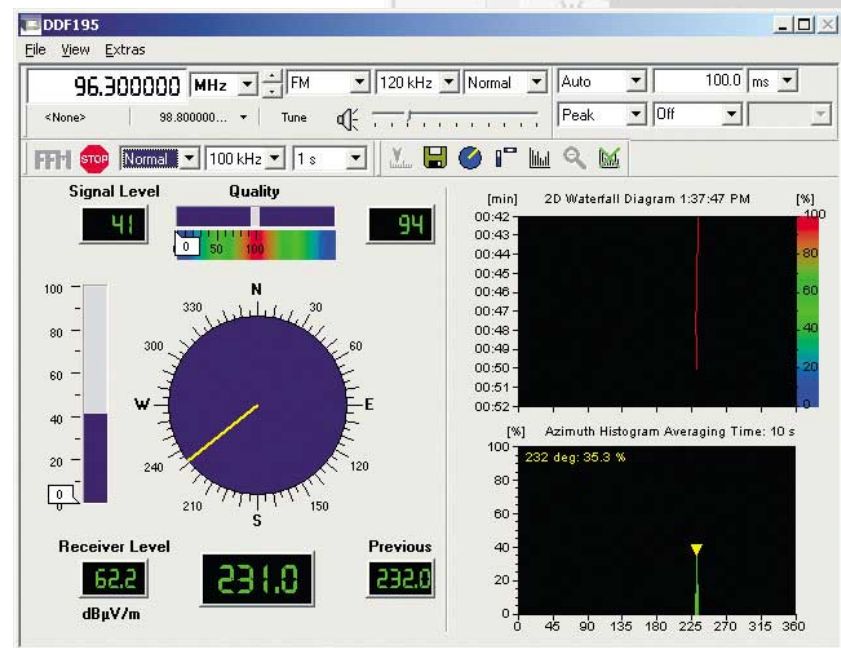

The **automatic measurement mode** is used to control all the equipment according to a schedule. The measurement results can be evaluated while the task is being performed or after it has been completed.

The measurement results can be saved in both modes. The measurement results can be evaluated directly on the PC by means of the evaluation module or they can be transferred to another monitoring center by saving the data to a CD-ROM (CD-RW is available on R&S SPCN and R&S SPCC) or, if available, via the communication units.

With the **evaluation module**, a comprehensive statistical evaluation of measurement results in accordance with the standards and recommendations of ITU-R is possible. Measurement results, their definitions and statistical analyses can also be documented in reports.

For more information, please refer to the technical information on R&S ARGUS.

Geographic Information Software R&S MapView

R&S MapView is used to display direction finding and radiolocation results on digital maps. The transmitter-site display supports the DF evaluation. Another application is displaying results obtained by coverage measurements.

The R&S MapView software is used to display geographic data on digital vector and raster maps. It was primarily designed for radiomonitoring and radiolocation applications and this is why the online result display is fast and has features optimized for this task. The digital maps are easy to work with by virtue of the range of functions that are available, for example:

- ◆ Fast map zooming
- ◆ Measurement of distances and directions
- ◆ Direct selection of map objects as well as direction finding and radiolocation results
- ◆ Rapid finding of map objects by means of the tree next to the window

For more information, please refer to the R&S MapView data sheet.

Integrated Digital Audio Software R&S AllAudio

R&S AllAudio is used in the systems to transfer, record, replay and distribute the audio signals of the receiver. The recordings are stored on the controller in an audio database. The operator can set bookmarks during recording and replay to find the recording quickly later on. Comments can also be added.

For more information, please refer to the R&S AllAudio data sheet.

Further information

Further information on the R&S ARGUS system family is available on the Internet at www.argus.rohde-schwarz.com, or from your local Rohde & Schwarz representative.

Information can also be obtained by e-mail to argus@rohde-schwarz.com.

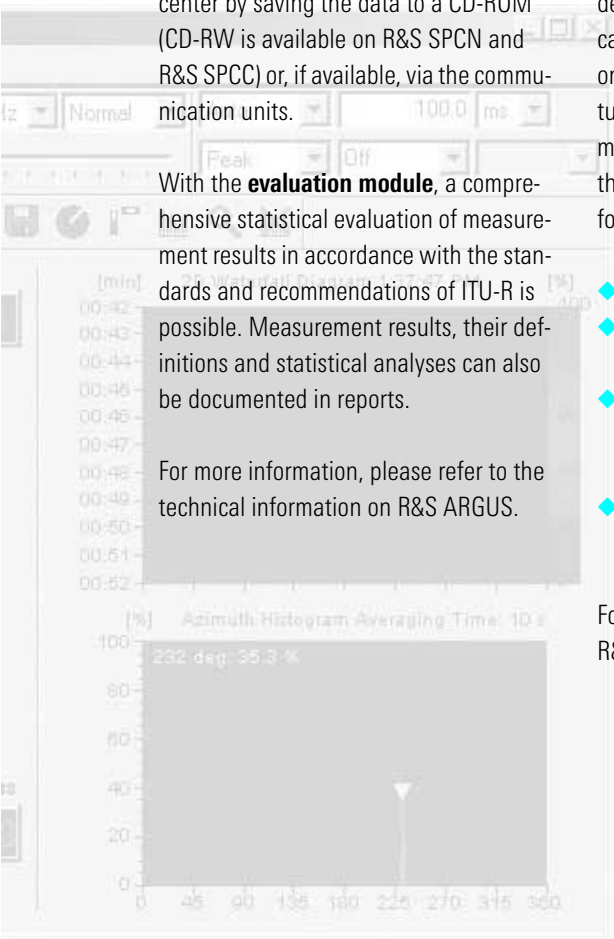

Certified Environmental System
ISO 14001
REG. NO 1954

Certified Quality System
ISO 9001
DQS REG. NO 1954

Specifications

R&S TMS 100

General data	
Operating temperature range	–10°C to +50°C with option R&S TMS-B1: –10°C to +45°C with option R&S TMS-B1 and option R&S TMS-B4: –10°C to +50°C
Storage temperature range	–40°C to +70°C
Humidity	80% cyclic, +25°C/+40°C
Sinusoidal vibration	5 Hz to 150 Hz
Random vibration	10 Hz to 500 Hz
Shock	40 g shock spectrum
EMC	meets EMC directive of EU (89/336/EEC) and German EMC law
Quality standard	developed and manufactured in compliance with ISO 9001
Power supply	100 V to 240 V AC/47 Hz to 63 Hz/290 VA with option R&S TMS-B1: additionally 65 VA 11 V to 32 V DC/205 W with option R&S TMS-B1: additionally 45 W
Dimensions (W x H x D) (box)	555 mm x 358 mm x 720 mm
Weight of fully equipped portable rack	42.7 kg with R&S TMS-B1: plus 6.6 kg

R&S TMS200

General data	
Operating temperature range	–10°C to +55°C with option R&S TMS-B1: –10°C to +45°C with option R&S TMS-B1 and option R&S TMS-B4: –10°C to +50°C
Storage temperature range	–40°C to +70°C
Humidity	95% cyclic, +25°C/+55°C with option R&S TMS-B1: 80% cyclic, +25°C/+40°C
Sinusoidal vibration	5 Hz to 150 Hz
Random vibration	10 Hz to 500 Hz
Shock	40 g shock spectrum
EMC	meets EMC directive of EU (89/336/EEC) and German EMC law
Quality standard	developed and manufactured in com- pliance with ISO 9001
Power supply	100 V to 240 V AC/47 Hz to 63 Hz/226 VA with option R&S TMS-B1: additionally 65 VA with option R&S ZS129A1: additionally 75 VA 11 V to 32 V DC/235 W with option R&S TMS-B1: additionally 45 W with option R&S ZS129A1: additionally 50 W
Dimensions (W x H x D) (box)	555 mm x 358 mm x 720 mm
Weight of fully equipped portable rack	40.1 kg with option R&S TMS-B1: plus 6.6 kg with option R&S ZS129A1: plus 5.5 kg

Ordering information

Designation	Type	Order No.
Basic versions		
Transportable Monitoring and Direction Finding System <i>R&S EB200 with Digi-Scan, IF panorama, LAN interface, two battery packs and carrying bag, R&S HE200, R&S SPCC with keyboard and mouse, basic module of R&S ARGUS with R&S EB200 device driver, automatic measurement mode and evaluation module, communication unit for network connection via analog dialled or leased line, hub, power distribution and portable rack</i> Note: To have a fully operational basic system, an antenna, the cable and a monitor must be included.	R&S TMS 100	3026.4519.02
Transportable Monitoring and Direction Finding System <i>R&S EB200 with Digi-Scan, IF panorama, LAN interface, two battery packs and carrying bag, R&S HE200, R&S SPCC with keyboard and mouse, basic module of R&S ARGUS with R&S EB200 device driver, automatic measurement mode and evaluation module, communication unit for network connection via dialled ISDN line, hub, power distribution and portable rack</i> Note: To have a fully operational basic system, an antenna, the cable and a monitor must be included.	R&S TMS 100	3026.4519.03

Ordering information (cont.)

Designation	Type	Order No.
Basic versions		
Transportable Monitoring and Direction Finding System <i>R&S EB200 with Digi-Scan, IF panorama, LAN interface, two battery packs and carrying bag, R&S HE200, R&S SPCC with keyboard and mouse, basic module of R&S ARGUS with R&S EB200 device driver, automatic measurement mode and evaluation module, communication unit for network connection via GSM/GPRS 900/1800, hub, power distribution and portable rack</i> Note: To have a fully operational basic system, an antenna, the cable and a monitor must be included.	R&S TMS100	3026.4519.04
Transportable Monitoring and Direction Finding System <i>R&S EB200 with Digi-Scan, IF panorama, LAN interface, two battery packs and carrying bag, R&S HE200, R&S SPCN with mouse, PCMCIA 2x serial port extension card and soft carrying bag, basic module of R&S ARGUS with R&S EB200 device driver, automatic measurement mode and evaluation module, hub, power distribution and portable rack</i> Note: To have a fully operational basic system, an antenna and the cable must be included.	R&S TMS200	3026.4619.02
Options		
R&S DDF195 for R&S TMSx <i>DF Processor R&S EBD195 with rack integration kit, DF Antenna R&S ADD195 (20 MHz to 1300 MHz) and R&S ARGUS Device Driver DDF1xx</i>	R&S TMS-B1	3026.7518.02
GPS Receiver and R&S ARGUS Device Driver GPS for R&S TMSx	R&S TMS-B2	3026.7560.02
External DC/AC Converter for R&S TMSx <i>Converts 11 V to 32 V DC to 230 V AC</i>	R&S TMS-B3	3026.7618.02
Front and Rear Cover for portable rack with opening for cables and fan for R&S TMSx	R&S TMS-B4	3026.7660.02
Adapter for R&S HE309/R&S HF902 mounted on Tripod R&S AC008-Z for R&S TMSx	R&S TMS-H1	3026.7260.02
5 m RF Cable for monitoring antennas for R&S TMSx	R&S TMS-H2	3026.7360.05
10 m RF Cable for monitoring antennas for R&S TMSx	R&S TMS-H2	3026.7360.10
20 m RF Cable for monitoring antennas for R&S TMSx	R&S TMS-H2	3026.7360.20
Grounding Set for antennas for R&S TMSx	R&S TMS-H3	3026.7418.02
Adapter for R&S ADD071 mounted on Tripod R&S AP502Z2 for R&S TMSx	R&S TMS-H4	3026.7460.02
Roof Rack Adapter for R&S ADD195 for R&S TMSx	R&S TMS-H5	3026.8766.02
Battery Pack with 24 V/26 AH for R&S TMSx	R&S TMS-H6	3026.8014.02
Case for R&S SPCN for R&S TMSx	R&S TMS-H7	3026.8066.02
Case for cables for R&S TMSx	R&S TMS-H8	3026.8114.02
Handheld Compass for R&S TMSx	R&S TMS-H9	3026.8166.02
Photo Tripod for R&S TMSx	R&S TMS-H10	3026.8189.02
Adapter for R&S HE010 mounted on photo tripod for R&S TMSx	R&S TMS-H11	3026.8214.02
Adapter for R&S HE500 mounted on photo tripod for R&S TMSx	R&S TMS-H12	3026.8266.02
Rack Integration Cable Set for R&S ZS129A1 for R&S TMS200	R&S TMS-ZSK	3026.6263.02

Further options are available on request.



ROHDE & SCHWARZ

ROHDE & SCHWARZ GmbH & Co. KG · Mühlendorfstraße 15 · 81671 München · Germany

P.O.B. 801469 · 81614 München · Germany · Telephone +49 89 4129-0 · Fax +49 89 4129-13247 · www.rohde-schwarz.com